

eGC

Autonomous Trace Toxic Chemical Monitor for Field Applications



PRODUCT HIGHLIGHTS

- **Fenceline monitoring**
- **Emissions trending**
- **Multi-component analysis**
- **ppb sensitivity**
- **Low cost of operation & sustainment**
- **Solar powered version**

eGC (environmental Gas Chromatograph) represents a new cost effective approach to gas chromatographic monitoring products for field applications. It is capable of multi-component analysis at trace environmental concentration levels, sub parts per billion, ideal for ambient air fenceline monitoring applications.

This product is a significant technological improvement over traditional process gas chromatograph's configured for ambient air monitoring. It is a fully autonomous instrument requiring no external carrier gas support. Additionally, it can be configured to operate using solar power, allowing convenience of deployment to remote areas. All analysis data is communicated via a cellular modem to the cloud where it can be easily accessed and shared. eGC has been tested to operate outdoors under harsh real world ambient conditions (-10 ° to 45°C) and is capable of the accuracy and precision of analytical laboratory instrument.

Using gas chromatography as its method of analysis, eGC separates the components of a workplace ambient air sample to allow the target chemicals to be easily detected. This allows a phased real time measurement of a variety of threat chemicals such as benzene or vinyl chloride in the field.

Analysis begins by collecting a composite air sample using a high volume transport fan, where a small air sample is collected for analysis; this sample is collected on the sample modulator or pre-column for analysis. This sample is transferred to the chromatographic column for separation. As the chemicals elute from the column they are detected by the sensor. The sensor measures a change of state or difference over time, which causes the sensor baseline frequency shift at a specific time for a specific chemical. This change will be compared to the reference calibration and the result will be reported in concentration units typically ppb (parts per billion). The typical sample analysis takes 2 to 5 minutes to complete and the cycle repeats on a continuous basis.

eGC is very economical to deploy and sustain in the field. Calibration checks are run as programmed to a known standard at a specific time and interval. The general service interval is 6 months where you would replace only the carrier scrubber. eGC is a next generation solution for trace chemical fenceline analysis for broad spectrum of industrial chemicals.

GENERAL SPECIFICATIONS

Analysis Range: 0.5ppbv to 200 ppbv (Benzene)

Analysis Time: 10 minutes

User Interface: Web

External Communication: Cellular Modem

Back up Data: USB memory drive

Calibration Frequency: User programmable

Carrier Gas Scrubber: >10,000 hours

Input Power: 12 VDC / Solar panel option

Operating Temperature: -10 to 45°C or 14° to 113°F

Dimensions: 44.5 x 49.5 x 21.3 cm
19.5 x 19.5 x 9.5 inches

Weight: 44 lbs, 19.95Kg

DIMENSIONS

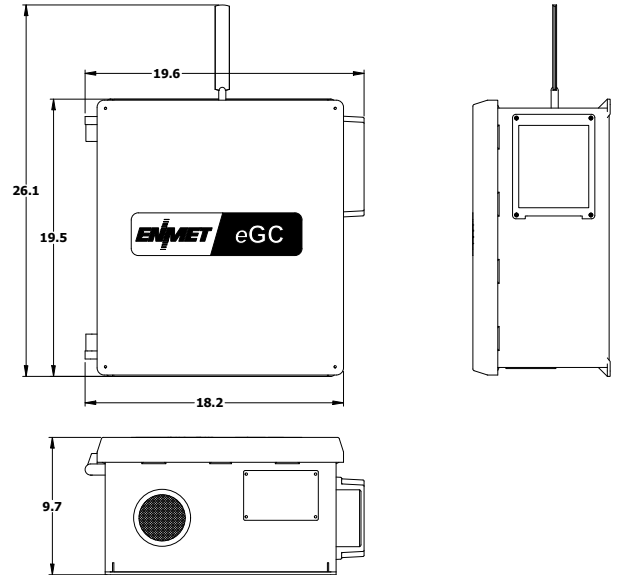

ORDERING INFORMATION

Contact ENMET sales department for a list of applications and product ordering information.

GASES

