



LC-8 Controller

Operation and Maintenance Manual

Table of Contents

1.0 INTRODUCTION	2
1.1 Unpack.....	2
1.2 Check Order.....	2
1.3 Serial Numbers.....	2
2.0 FEATURES	4
2.1 Front panel features.....	4
3.0 INSTALLATION	5
3.1 Mounting LC-8 Control Unit.....	5
3.2 Wiring the LC-8 Controller I/O Circuitry.....	6
3.2.1 System Wiring.....	6
3.2.2 Power Supply Module.....	7
3.2.3 LC-8 Controller Field Connections.....	8
3.3 Sensor Transmitter Installation.....	9
3.3.1 Example 2 Wire Sensor Transmitter.....	9
3.3.2 Example 3 Wire Sensor Transmitter.....	9
4.0 OPERATION	10
4.1 LC-8 Microcontroller Module.....	10
4.2 Analog Output Configuration.....	13
4.2.1 4-20mA Current Source.....	13
4.2.2 4-20mA Current Sink.....	14
4.2.3 – 5V Voltage Output.....	15
5.0 REPLACEMENT PARTS	16
6.0 TECHNICAL DATA AND SPECIFICATIONS	16
7.0 TERMS AND CONDITIONS	18
7.1 Ordering Information.....	18
7.2 Delivery.....	18
7.3 Payment Terms.....	18
7.4 Warranty Information and Guidelines.....	18
7.5 Return Policy.....	18
8.0 INSTRUCTIONS FOR RETURNING AN INSTRUMENT FOR SERVICE	19

List of Figures

Figure 1: LC-8 Front Panel.....	4
Figure 2: Mounting LC-8.....	5
Figure 3: LC-8 Features.....	10
Figure 4: LC-8 Display Contrast Adjustment.....	11

1.0 Introduction

The LC-8 Controller provides up to 8 monitoring channels.

The LC-8 Controller has been designed to allow the use of any ENMET sensor transmitter and has been preprogrammed to match the sensor transmitters supplied at time of delivery. The LC-8 can also be used with any manufactures sensor transmitter that can produce a voltage or current output within a specified range; however, it is advisable that you contact ENMET for proper setup and programming instructions.

Care has been taken with the design of the MCU housings and internal chassis to facilitate ease of connection and wire termination. All on-site wiring to the system is via screw terminal connectors. The terminal cover has an internal label giving details of the external connections.

NOTE: *All specifications stated in this manual may change without notice.*

1.1 Unpack

Unpack the LC-8 Controller and examine it for shipping damage. If such damage is observed, notify both ENMET customer service personnel and the commercial carrier involved immediately.

Regarding Damaged Shipments

NOTE: *It is your responsibility to follow these instructions. If they are not followed, the carrier will not honor any claims for damage.*

- This shipment was carefully inspected, verified and properly packaged at **ENMET** and delivered to the carrier in good condition.
- When it was picked up by the carrier at **ENMET**, it legally became your company's property.
- If your shipment arrives damaged:
 - Keep the items, packing material, and carton "As Is." Within 5 days of receipt, notify the carrier's local office and request immediate inspection of the carton and the contents.
 - After the inspection and after you have received written acknowledgment of the damage from the carrier, contact **ENMET** Customer Service for return authorization and further instructions. Please have your Purchase Order and Sales Order numbers available.
- **ENMET** either repairs or replaces damaged equipment and invoices the carrier to the extent of the liability coverage, usually \$100.00. Repair or replacement charges above that value are your company's responsibility.
- The shipping company may offer optional insurance coverage. **ENMET** only insures shipments with the shipping company when asked to do so in writing by our customer. If you need your shipments insured, please forward a written request to **ENMET** Customer Service.

Regarding Shortages

If there are any shortages or questions regarding this shipment, please notify **ENMET** Customer Service within 5 days of receipt at the following address:

ENMET
680 Fairfield Court
Ann Arbor, MI 48108
734-761-1270 Fax 734-761-3220
Toll Free: 800-521-2978

1.2 Check Order

Check the contents of the shipment against the purchase order. Verify that the LC-8 Controller is received as ordered. Each LC-8 Controller is labeled with its target gas. If there are accessories on the order, ascertain that they are present. Check the contents of calibration kits. Notify ENMET customer service personnel of any discrepancy immediately.

1.3 Serial Numbers

Each LC-8 Controller is serialized. These numbers are on tags on the equipment and are on record in an ENMET database.

2.0 Features

The LC-8 Controller houses all the components required to implement a sophisticated and reliable monitoring system (alarm relays etc.). See Figure 1 for location of features:

2.1 Front panel features

See Figure 1 for location of features.

LED	Description
Power	Green LED for Power
AL3	Red LED indication of Alarm Level 3
AL2	Red LED indication of Alarm Level 2
AL1	Red LED indication of Alarm Level 1
Fault	Yellow LED, Lower most, indication of Fault Condition
Keypad Buttons, 4 2 as indicated in figure 1 that are used during normal operation and 2 that are used during setup and programming	Menu – Main Select Switch Increase – Menu Option, used in setup & programming Decrease – Change Switch, used in setup & programming Alarm Acknowledgment – Horn Audio Silence Switch
Display	Graphic display simultaneously showing reading for each channel and sensor type

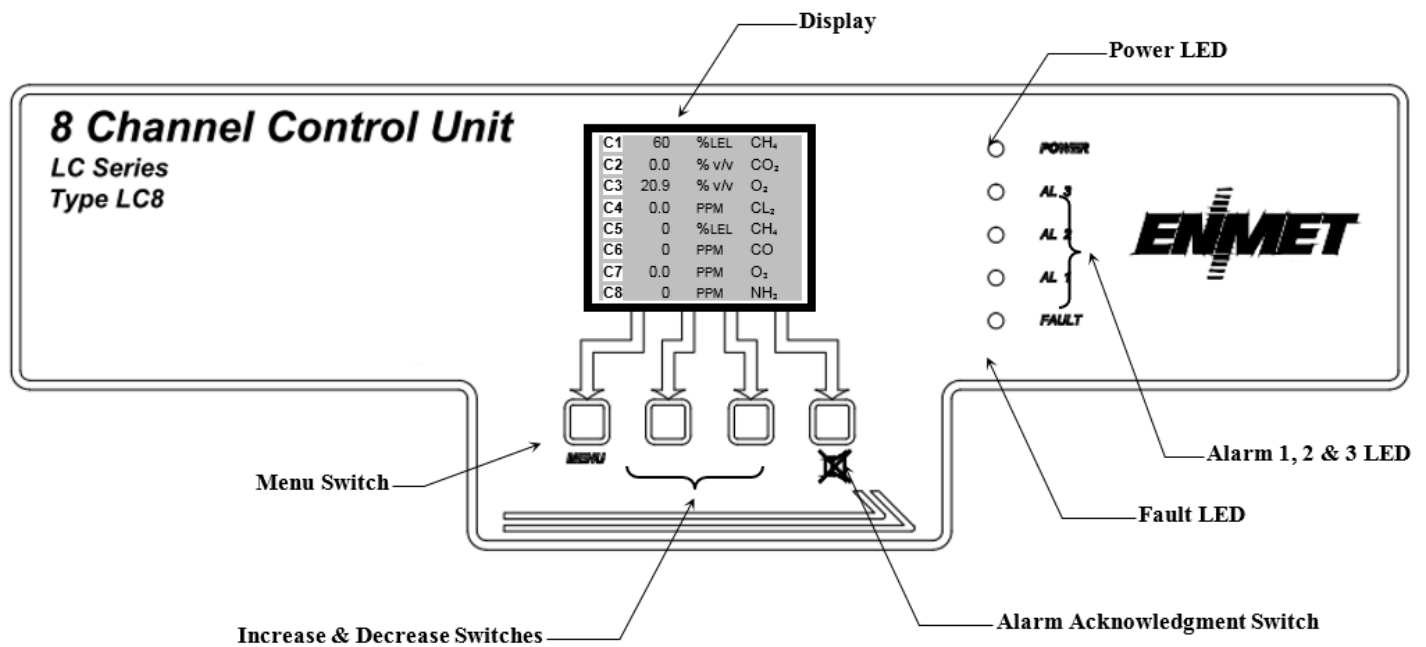

Figure 1: LC-8 Front Panel

3.0 Installation

The **LC-8 Controller** is fully tested prior to delivery. However, it is recommended that the **LC-8 Controller** system be checked after installation is complete

3.1 Mounting LC-8 Control Unit

The **LC-8 Controller** control units must be installed in a non-hazardous location where there is no risk of the presence of potentially explosive gas.

Either a 100-240VAC 60 Hz supply or a 24V DC supply can be used to power the control unit.

The location of installation should be chosen about the following:

- This equipment should not be located near to known sources of heat.
- Operating personnel should be within convenient reach of the equipment and within audible distance of alarms.
- Maximum loop lengths of cable runs and cable inductance to resistance ratios must not exceed limits shown in the relevant loop diagrams (refer to section).
- Avoid mounting this equipment near potential sources of electrical interference e.g. motors, switch gear, radio transmitters etc.

Mounting dimensions for the **LC-8 Controller** are shown in Figure 2 below.

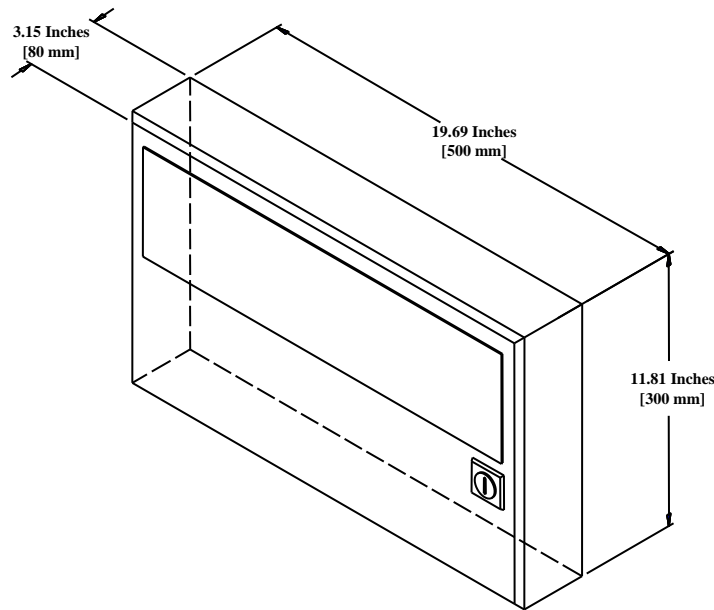

Figure 2: Mounting LC-8

3.2 Wiring the LC-8 Controller I/O Circuitry

The electrical installation should conform to appropriate electrical codes, such as the National Electrical Code in the United States.

WARNING: *The compliance of the installation to appropriate codes is not ENMET's responsibility.*

3.2.1 System Wiring

All connections should be made per the appropriate sensor or loop diagram for the configuration required.

Power Supply Input

It is recommended that the LC-8 Controller be connected to a dedicated power source that incorporates over current protection such as a circuit breaker or fuse.

AC mains Connection

The LC8 is powered from a mains supply that is housed within the enclosure.

The power supply has a 6-way screw terminal connector assigned for the connection of an AC supply.

- Pin 1 = Live input
- Pin 2 = Neutral input
- Pin 3 = Earth

Recommendation for mains input cable:

3-Core – 16 awg Conductors having cross sectional area of approximately 0.75mm² minimum (24/0.2).

The output from the mains power supply is

- Pin 4 = N/C
- Pin 5 = 0V DC
- Pin 6 = +24V DC

DC Voltage Connection

The main PCB has two DC inputs.

Internal supply:

- Pin 1 = +24V DC input
 - Pin 2 = 0V DC input
- External supply, that may be a battery back-up supply.
- Pin 3 = +24V DC input
 - Pin 4 = 0V DC input

NOTE: *The two supplies are connected after two reverse blocking diodes. This means that the supply that has the highest voltage will power the system.*

WARNING: *Some switch mode battery chargers may damage the processor and display, consult ENMET for advice.*

Located on the lower half of the main PCB are several screw connectors. This is used to provide connections for inputs and outputs for each channel:

3.2.2 Power Supply Module

The Power Supply is situated on the right-hand side of the main PCB within the enclosure and provides the power for the whole system. The power supply is a standard item and does not require any modifications regardless of the type and quantity of detector heads being used.

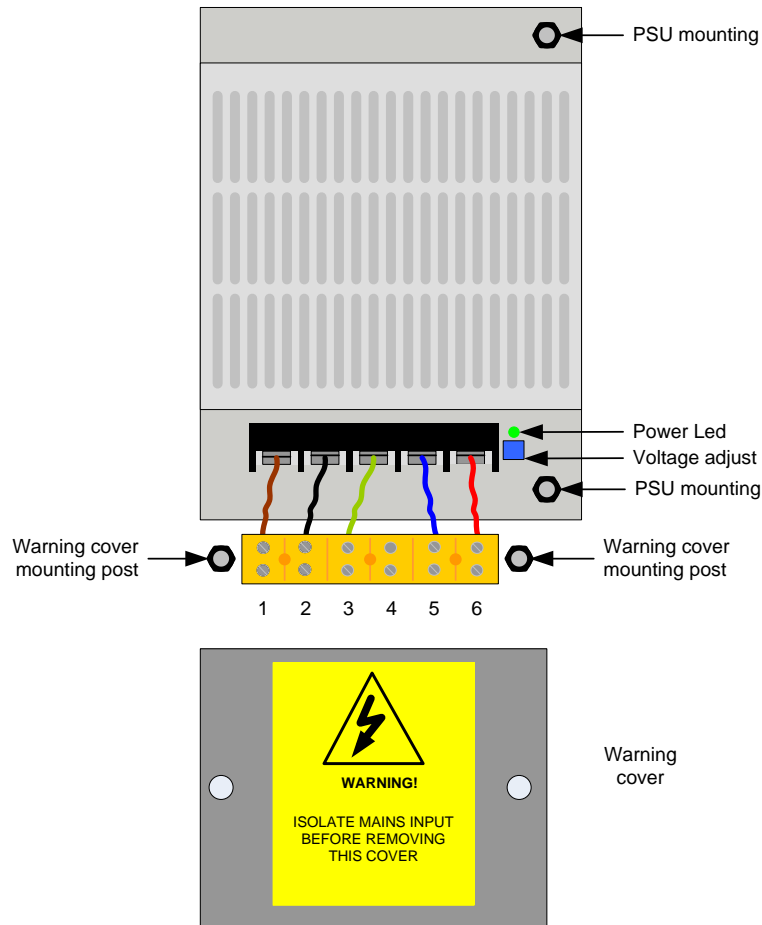

The warning cover must be removed to gain access to the terminal connections. The power supply connections are as follows:

1	Live 100-240V AC Mains supply input.
2	Neutral 100-240V AC Mains supply input.
3	Earth 100-240V AC Mains supply input.
4	No connection
5	-Ve DC supply output.
6	+Ve DC supply output.

The Power input, common relays and audio alarm (horn) output are located at the lower right hand side of the PCB. SW1 is used to isolate the main circuitry from the 24VDC power source SW1 must be in the ON Position for the **LC-8 Controller** to operate both the incoming power supplies.

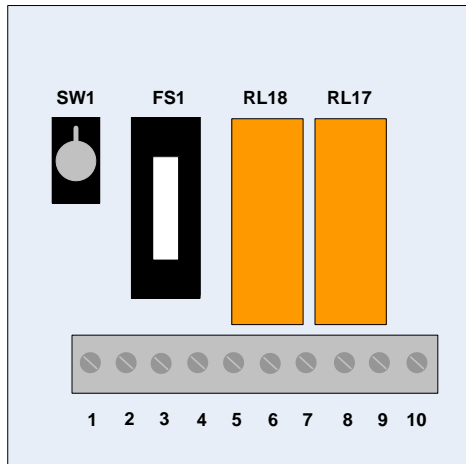

1	Fused power input +Ve 24Vdc. Fused on PCB, FS1
2	Fused power input -Ve.
3	Battery power input +Ve 24Vdc, fused on PCB, FS1.
4	Battery power input -Ve.
5 & 6	Fault relay contacts, RL18.
7 & 8	Common alarm level 3 relay contacts, RL17.
9	Audio alarm +Ve 24Vdc.
10	Audio alarm -Ve supply.

3.2.3 LC-8 Controller Field Connections

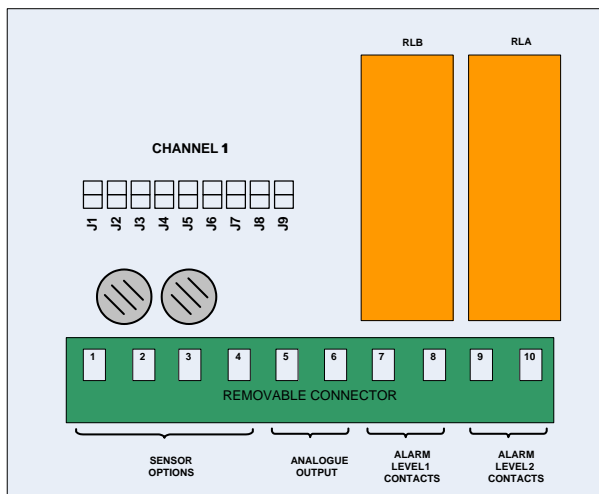

Cable Routing

Due to the low signal levels generated by gas detectors it is recommended that all wiring to the sensors be segregated away from AC mains or other high voltage/power lines to avoid interference.

Cable Sensor Transmitters

The use of a shielded cable or metal conduit is recommended for the installation of all detector heads. The shielding or metal conduit is used to minimize the effects of electrical interference generated by external equipment e.g. motors, switchgear etc. The correct strategy for connecting the shielding depends upon the area in which the detector head is to be used (i.e. hazardous/ non-hazardous) see local codes. In all cases the shielding should not be connected at the detector head

3.3 Sensor Transmitter Installation

Mounting location for the gas detectors need to be considered individually, initial points for consideration are:

- Ensure all gas detectors are mounted to allow routine calibration and maintenance to be carried out as required.
- Ensure the proposed site will not interfere with movement of existing equipment, e.g. cranes, doors etc
- Install all cables neatly and securely.
- Detectors for gases that are lighter than air should be positioned at, or below, a high level.
- Detectors for gases that are heavier than air should be located at below head height.
- Avoid location the gas detectors adjacent to potential sources of radio frequency interference, e.g. radio transmitters, control switchgear, motors etc.
- Ensure the detectors are mounted with sufficient space to allow air movement around the sensor section.

3.3.1 Example 2 Wire Sensor Transmitter

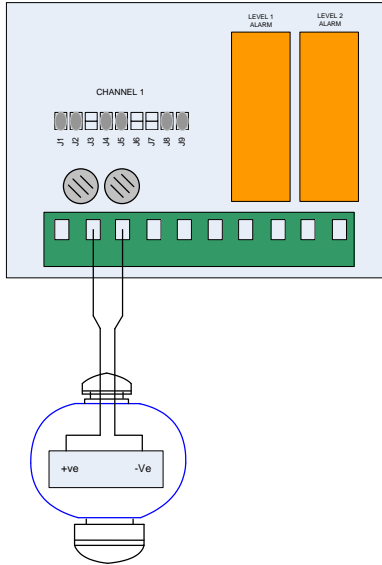

3.3.2 Example 3 Wire Sensor Transmitter

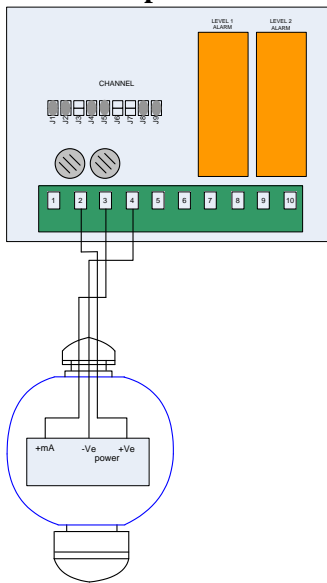

4.0 Operation

When a preset alarm point is reached, visual and/or audio alarms are activated. The backlit graphics display automatically displays the channel in alarm and an alarm level Led(s) are activated on the control panel. The LC-8 is factory set to maintain these alarms until they are acknowledged.

4.1 LC-8 Microcontroller Module

Situated within the **LC-8 Controller** front panel is the Microcontroller Module. This module communicates with all Input channels connected to the system PCB.

The Microcontroller Module provides a user interface in the form of a backlit graphics display and a four-button multifunction keypad. Primary displays are Operation and Configuration. From the configuration display sub category displays are available for controller, channel, and transmitter configuration.

Note: *If sensor transmitters were supplied with the LC-8 controller at time of shipment all configurations have been done at ENMET prior to shipment.*

Five LED indications are provided directly by the Microcontroller Module and these are visible via LC-8 front panel:
Example of use: From the operational display Push the MENU switch *one* time the configuration display will be shown. Then press the NEXT switch until Channel is highlighted.

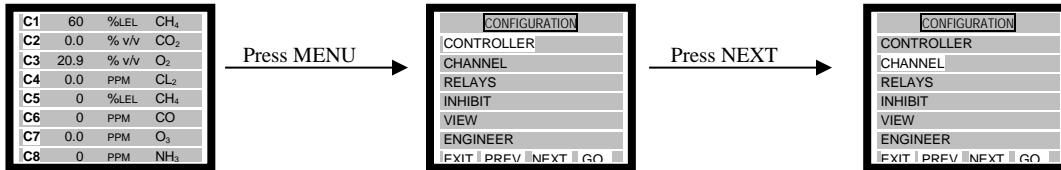

Then press the GO switch *twice* you will see figure 3 below

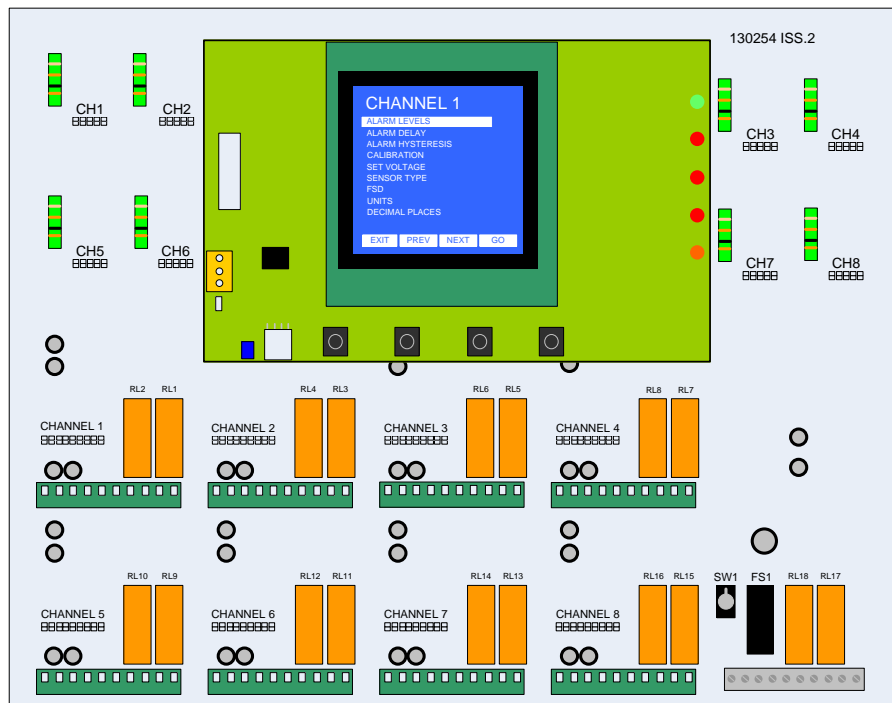

The diagram above shows a pictorial representation of the various module positions within the LC8 Control Units

Figure 3: LC-8 Features

The Microcontroller Module also provides the user with many configuration and interrogation facilities via the LCD and keypad. These facilities include:

Sensor Configuration:

- Allows choice of Sensor type and range (e.g. Flammable 100%LEL).

Configuration of the System:

- This allows each channel to be calibrated independently.
- Allows each channel Zero and Sensor to be trimmed to match a sensor/transmitter.
- Calibration of the retransmitted output for each channel.
- DC output Calibrates and output value of the DC power supply.

Input Module Relay Configuration:

- Each Input Module contains two relays for alarm levels 1 and 2. The alarm levels can be individually set to be either rising or falling.
- Fault relay.
- All relays can be configured normally energized or de-energized as required. Latching and non-latching functions can also be selected. Factory set to energized and latching.



Figure 4: LC-8 Display Contrast Adjustment

NOTE: In some applications, slight electronic noise between the Sensor/Transmitter and the Control can cause fluctuations in the display reading. These minor fluctuations are insignificant in terms of the range, detection limit and alarm values of the gas being monitored.

The input circuit is identical for all channels. Each channel monitors the status of an externally attached sensor transmitter and interfaces the signals that it receives to the microcontroller module.

The input module is designed to accommodate modules that supply the status signal in any of the following formats:

- 2-Wire Current source 4 – 20mA.
- 3-Wire power plus Current source 4 – 20mA.

The channel outputs are as follows.

The transmitted signal can be configured using jumpers to provide one of three output options:

- 4 – 20mA Current Source proportional to the detected signal.
- 4 – 20mA Current Sink proportional to the detected signal.
- 0-5V Voltage Output proportional to the detected signal.

Relays

Situated on each Input Module are 2 single-pole change-over relays, each relay having contacts rated at 5A (240V AC). These relays operate at the alarm levels when enabled. It is recommended that if these relays are used a dedicated power source separate from the LC-8 be used to insure alarm activation occurs in the event that the power to the LC-8 is interrupted.

Note:

- 1) *The relays are selected to be either normally open or normally closed by solder links on the underside of the PCB. The factory default settings are closed contacts when the power is off. This setting has been chosen such that the channel is in an alarm condition when the power fails.*
- 2) *The solder links are on the underside of the PCB to meet the low voltage directive and make sure that the user is not exposed to bare terminals that may be at high voltages when switching mains voltages.*

There are two solder links under each relay. The link must be made for the desired operation. Only 1 of the links must be made. The factory default setting is shown below, the relay is energized for healthy condition, the contacts will close for an alarm condition and loss of power.

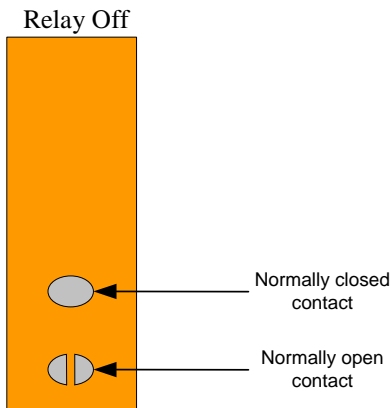

4.2 Analog Output Configuration

In addition to providing the connections for various connector types, the Input Module can also provide an analog output. This output mimics the signal detected so that it may be used by external equipment (e.g. chart recorders, data loggers) for a variety of purposes.

4.2.1 4-20mA Current Source

Factory default settings

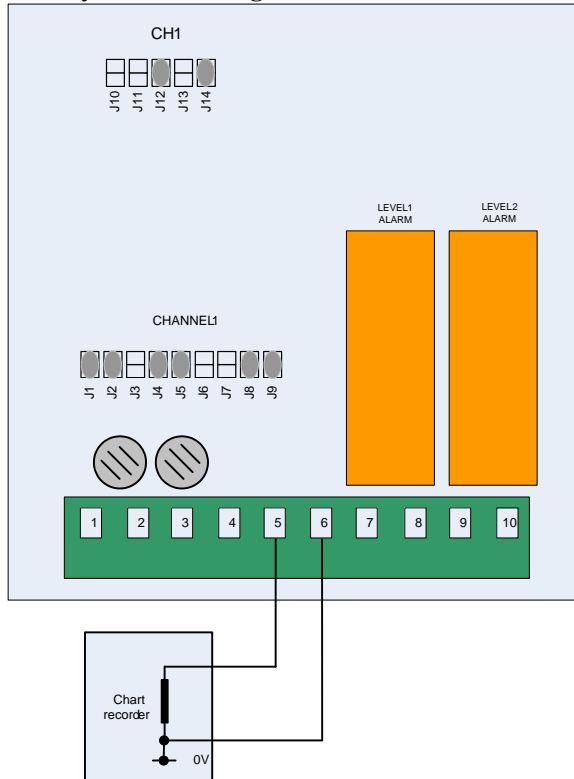

The Input Module sources current proportional to the detected gas level.

i.e. zero gas = 4mA
 full scale = 20mA

The supply is taken from the internal PSU. Switch ON J12 and J14

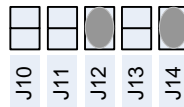

NOTE: Incorrect jumper switch configuration can cause damage to the system.

4.2.2 4-20mA Current Sink

Optional Setting

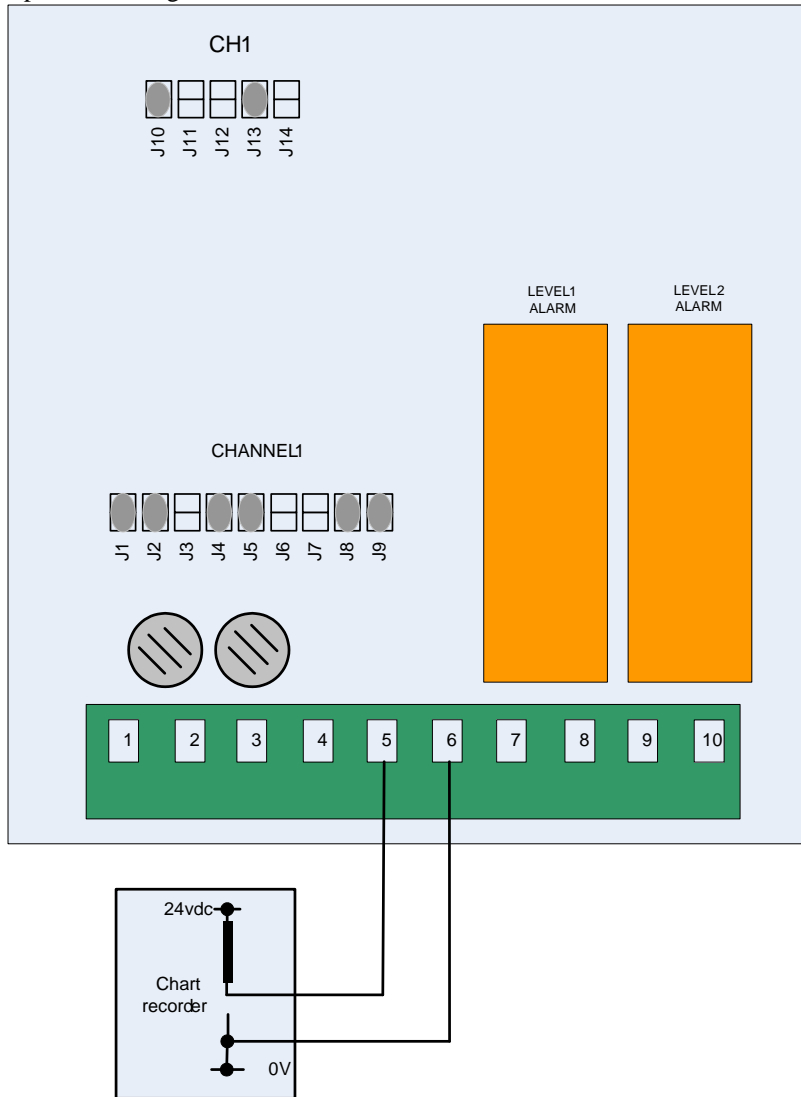

The Input Module can also sink current proportional to the detected gas level.
 i.e. zero gas = 4mA
 full scale = 20mA

The supply is derived from the external equipment.

Switch ON J10 and J13

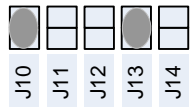

NOTE: Incorrect jumper switch configuration can cause damage to the system.

4.2.3 – 5V Voltage Output

Optional setting

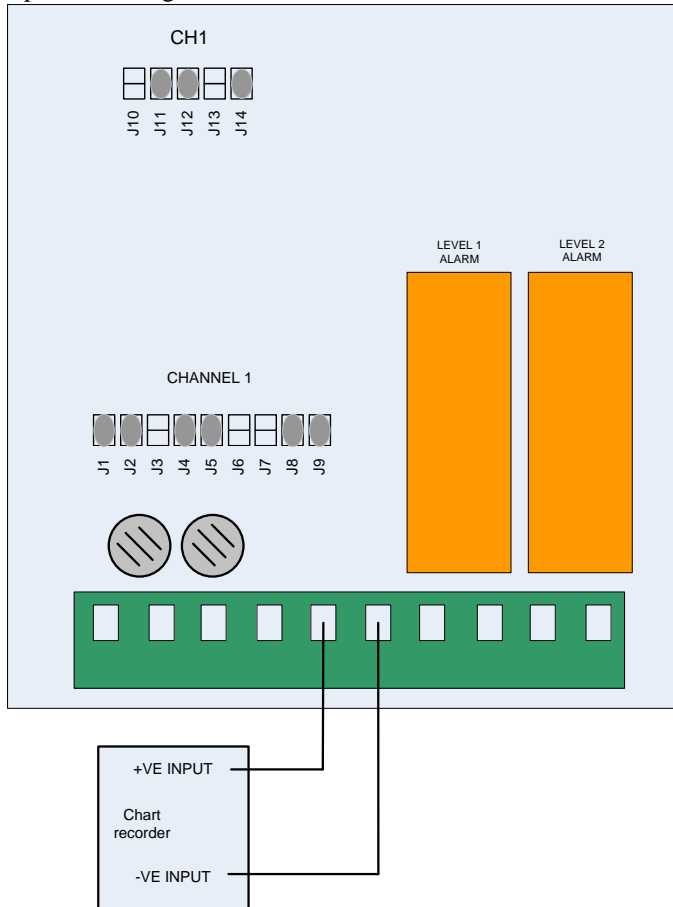

The LC Control Unit can provide a voltage output.
 i.e. zero gas = 1V
 full scale = 5V

This output is not ideal when transmitting a signal over a large distance. The resistance of a cable attached will cause a voltage drop to occur.

Links ON J11, J12 and J14.

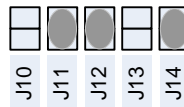

NOTE: Incorrect link configuration can cause damage to the system.

5.0 Replacement Parts

Contact *ENMET*

6.0 Technical Data and Specifications

Electrical Power	Input Voltage	18 – 28 VDC, or 100-240 VAC 50/60 Hz
	Fuse 1	T2.0A located next to power input connector
	Switch	DC isolation switch next to Fuse holder
Storage and Transport	Temperature:	-4°F to +122°F (-20°C to +50°C)
Operation	Temperature	-14°F to +122°F (-10°C to +50°C)
	Relative Humidity	0 to 95% RH Non-condensing
Mechanical	Dimensions	19.7 x 11.8 x 3.15 inches (500x300x80 mm)
	Weight	17 lbs (7.7 Kg)
	Display	LED Backlit 128 x 128 dot Liquid Crystal (LCD) 2.25 x 2.25 inches (57 x 57 mm)
	Keyboard	4 Button Multifunction Keypad
	Number of Channels	8 Maximum
Outputs	Number of Channels	8 Maximum
	Relay – 18	1relay assigned to alarm level 1, channel 1 to 8 1relay assigned to alarm level 2, channel 1 to 8 1relay assigned to common alarm level 3 1relay assigned to fault condition
	Contacts Rating	Single Pole Changeover Contacts (voltage free), N/O or N/C selected by links on underside or PCB 5A 240VAC
Audio	Buzzer	95dB at 1 ft. (30 cm)

NOTE: All specifications stated in this manual may change without notice.

Notes:

7.0 Terms and Conditions

7.1 Ordering Information

Address orders to:

ENMET

Attention: Customer Service Department
680 Fairfield Court
Ann Arbor, MI 48108

Email Orders: orderentry@enmet.com

Phone: 734-761-1270

Fax: 734-761-3220

You may also contact our customer service department by email info@enmet.com. MINIMUM ORDER IS \$50.00.

7.2 Delivery

Unless Seller otherwise specifies, delivery will be made: FOB Ann Arbor, MI and/or FOB Bowling Green, KY. Title and risk of loss shall pass to Buyer at that point. Shipping and handling charges will be Prepaid and Added to Buyer's invoice. Buyer may request shipping be charged to their own account with a preferred carrier. Seller shall have the right to choose means of transportation and to route shipment when specific instructions are not included with Buyer's order. Seller agrees to deliver the goods and services, within the time, in accordance with specifications, at the prices specified on the face hereof. Buyer's orders to this quotation are not subject to cancellation or deferment of delivery without indemnification of loss to the Seller resulting therefrom. Seller shall not be liable to Buyer for any loss or damage sustained on account of this delay or nonperformance due to causes beyond Seller's control and without his fault or negligence. Where performance of the terms here is contingent upon timely delivery of goods or services by the Buyer and such delivery is in default, Seller shall be indemnified for any damage or loss resulting therefrom, and/or by extension of Seller's delivery commitment, as applicable.

7.3 Payment Terms

Payment Terms are Net 30 Days from the date of shipment from Seller unless otherwise noted. All shipping and handling costs will be charged to Buyer on a Prepaid and Add basis. Buyer has the option of paying for shipping by charging its own account with a carrier

7.4 Warranty Information and Guidelines

The Seller warrants new instruments to be free from defects in workmanship and material under normal use for a period of one year from date of shipment. The warrant covers both parts and labor excluding calibration and expendable parts such as filters, detector tubes, batteries, etc. If the inspection by the Seller confirms that the product is defective, it will be repaired or replaced at no charge, within the stated limitations, and returned prepaid to any location in the United States. The Seller shall not be liable for any loss or damage caused by the improper use or installation of the product. The Buyer indemnifies and saves harmless the Seller with respect to any loss or damages that may arise through the use by the Buyer or others of this equipment. This warranty is expressly given in lieu of all other warranties, either expressed, implied or statutory, including that of merchantability, and all other obligations, or liabilities of ENMET, LLC for damages arising out of or in connection with the use or repair or performance of the product. In no event shall ENMET, LLC, be liable for any indirect, incidental, special or consequential damages or for any delay in the performance by ENMET, LLC, which may arise in connection with this equipment. ENMET neither assumes nor authorizes any representatives or other persons to assume for it any obligation or liability other than that which is set forth herein. Buyer agrees to indemnify and save harmless Seller for any damage or loss from lawsuits against Seller by reason of manufacture of sale of materials, parts, or use of processes resulting from Buyer's design specifications. Any patent, design, pattern, tool, die, jig, fixture, drawing, test equipment, or process furnished by Seller; whether possessed by the Seller before the date of this quotation, or devised or acquired by Seller during performance of the terms of this quotation, shall remain the property of the Seller except by specific stipulation on the face hereof. Seller reserves the right, without liability, for damage or loss, to destroy Buyer's drawings, specifications, patterns and special tools supplied by Buyer for performance of the terms on the face hereof, unless Buyer gives notice of the disposition of such items.

7.5 Return Policy

All returns for credit must be approved in advance by ENMET, LLC. Such returns are subject to a minimum \$50.00 or 20% restocking charge, whichever is greater. **Approval of equipment for return is totally at the discretion of ENMET, LLC.** All requests for return/exchange must be made no later 30 days of the original shipping date from ENMET. The actual amount of any resulting credit will not be determined prior to a complete inspection of the equipment by ENMET. Calibration gas cylinders cannot be returned or restocked.

8.0 Instructions for Returning an Instrument for Service

Contact the ENMET Service Department for all service requests.

Phone: 734-761-1270

Email: repair@enmet.com

Fill out the “Service Request Form” found at the end of this manual and return with your instrument for all needs. Please send your instrument for service to the site in which the product was purchased. A new “Service Request Form” may be requested if the one found in the manual is not available. All instruments should be shipped prepaid to ENMET.

Address for Service:

Michigan Location:

ENMET
Attention: Service Department
680 Fairfield Court
Ann Arbor, MI 48108

Kentucky Location:

ENMET
62 Corporate Court
Bowling Green, KY 42103

Providing the “Service Request Form” assists in the expedient service and return of your unit and failure to provide this information can result in processing delays. **ENMET** charges a one hour minimum billing for all approved repairs with additional time billed to the closest tenth of an hour. All instruments sent to **ENMET** are subject to a minimum evaluation fee, even if returned unrepared. Unclaimed instruments that **ENMET** has received without appropriate paperwork or attempts to advise repair costs that have been unanswered after a period of 60 days may, be disposed of or returned unrepared COD and the customer will be expected to pay the evaluation fee. Serviced instruments are returned by UPS/FedEx Ground and are not insured unless otherwise specified. If expedited shipping methods or insurance is required, it must be stated in your paperwork.

NOTE: *Warranty of customer installed components.*

For Warranty Repairs, please reference **ENMET's** “Warranty Information and Guidelines” (found earlier in this section).

Mailing/Shipping Address:

ENMET
680 Fairfield Court
Ann Arbor, MI 48108
repair@enmet.com



Phone: 734.761.1270
Fax: 734.761.3220

Service Request Form

Product Name or Number:

Product Serial Number:

Describe Problem or Needed Service:

Warranty Claim? Yes No

CUSTOMER INFORMATION

Billing Address:

Shipping Address:

Contact Name: _____

Phone #: _____

Email: _____

Fax #: _____

PO/Reference #: _____

PAYMENT METHOD

COD VISA/MasterCard American Express

Card Number

Exp. Date

Security Code:

Name as it Appears on

Card: _____

RETURN SHIPPING METHOD

UPS Ground UPS 3 Day Select UPS Next Day Air UPS ND Air Saver UPS 2 Day Air

UPS Account #: _____

FedEx Ground FedEx Air Express Saver FedEx Air Overnight Std. FedEx Air 2 Day FedEx Air Overnight P-1

FedEx Account #: _____

Insure Shipment: Yes No

Insurance \$
Amount: _____