

## LC-2 Controller Operation and Maintenance Manual

**Table of Contents**

**1.0 INTRODUCTION..... 2**

    1.1 Unpack ..... 2

    1.2 Check Order ..... 2

    1.3 Serial Numbers..... 2

**2.0 FEATURES ..... 3**

    2.1 Front Panel Features ..... 3

    2.2 Installation ..... 4

**3.0 WIRING THE LC-2 ..... 5**

    3.1 System Wiring ..... 5

        3.1.1 Power Supply Module ..... 6

        3.1.2 LC-2 Connections ..... 7

    3.2 Sensor Transmitter Installation ..... 8

        3.2.1 Example 2 Wire Sensor Transmitter ..... 8

        3.2.2 Example 3 Wire Sensor Transmitter ..... 8

**4.0 OPERATION ..... 9**

    4.1 LC-2 Microcontroller Module..... 9

    4.2 Connection Procedures ..... 9

    4.3 Analogue Output Configuration..... 10

        4.3.1 4-20mA Current Source ..... 11

        4.3.2 4-20mA Current Sink ..... 12

        4.3.3 1-5V Voltage Output ..... 13

**5.0 MAINTENANCE ..... 14**

**6.0 TECHNICAL DATA AND SPECIFICATION..... 15**

**7.0 TERMS AND CONDITIONS ..... 16**

    7.1 Ordering Information ..... 16

    7.2 Delivery ..... 16

    7.3 Payment Terms ..... 16

    7.4 Warranty Information and Guidelines ..... 16

    7.5 Return Policy ..... 16

**8.0 INSTRUCTIONS FOR RETURNING AN INSTRUMENT FOR SERVICE..... 17**

**List of Figures**

Figure 1: LC Series Front Panel Features ..... 3

Figure 2: Mounting the LC-2 ..... 4

Figure 3: Power Supply Module ..... 6

Figure 4: LC-2 Connections..... 7

Figure 5: 4-20mA Current Source ..... 11

Figure 6: 4-20mA Current Sink ..... 12

Figure 7: 1-5V Voltage Output ..... 13

**Reference Information:**

**NOTE:** [important information about use of instrument]

**CAUTION:** [affects equipment – if not followed may cause damage to instrument, sensor etc....]

**WARNING:** [affects personnel safety – if not followed may cause bodily injury or death.]

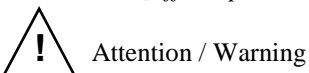

## 1.0 Introduction

The **LC-2** is a unit that allows facilities to monitor with a wide variety of industry standard environmental and other sensors. This product provides up to 2 monitoring channels.

The **LC-2** Controller has been designed to allow the use of any **ENMET** sensor transmitter and has been preprogrammed to match the sensor transmitter supplied at the time of delivery. The **LC-2** can also be used with any manufacturer's sensor transmitter that can produce a voltage or current output within a specified range; however, it is advisable that you contact **ENMET** for proper setup and programming instructions.

Care has been taken with the design of the MCU housings and internal chassis to facilitate ease of connection and wire termination. All on-site wiring to the system is via screw terminal connectors. The terminal cover has an internal label giving details of the external connections.

**NOTE:** *All specifications stated in this manual may change without notice.*

### 1.1 Unpack

Unpack the **LC-2** and examine it for shipping damage. If such damage is observed, notify both **ENMET** customer service personnel and the commercial carrier involved immediately.

### Regarding Damaged Shipments

**NOTE:** *It is your responsibility to follow these instructions. If they are not followed, the carrier will not honor any claims for damage.*

- This shipment was carefully inspected, verified and properly packaged at **ENMET** and delivered to the carrier in good condition.
- When it was picked up by the carrier at **ENMET**, it legally became your company's property.
- If your shipment arrives damaged:
  - Keep the items, packing material, and carton "As Is." Within 5 days of receipt, notify the carrier's local office and request immediate inspection of the carton and the contents.
  - After the inspection and after you have received written acknowledgment of the damage from the carrier, contact **ENMET** Customer Service for return authorization and further instructions. Please have your Purchase Order and Sales Order numbers available.
- **ENMET** either repairs or replaces damaged equipment and invoices the carrier to the extent of the liability coverage, usually \$100.00. Repair or replacement charges above that value are your company's responsibility.
- The shipping company may offer optional insurance coverage. **ENMET** only insures shipments with the shipping company when asked to do so in writing by our customer. If you need your shipments insured, please forward a written request to **ENMET** Customer Service.

### Regarding Shortages

If there are any shortages or questions regarding this shipment, please notify **ENMET** Customer Service within 5 days of receipt at the following address:

**ENMET**  
680 Fairfield Court  
Ann Arbor, MI 48108  
734-761-1270 Fax 734-761-3220  
Toll Free: 800-521-2978

### 1.2 Check Order

Check the contents of the shipment against the purchase order. Verify that the **LC-2** is received as ordered. Each **LC-2** Controller unit is labeled with its target gas. If there are accessories on the order, ascertain that they are present. Check the contents of calibration kits. Notify **ENMET** customer service personnel of any discrepancy immediately.

### 1.3 Serial Numbers

Each **LC-2** is serialized. These numbers are on tags on the equipment and are on record in an **ENMET** database.

## 2.0 Features

The LC-2 Controller houses all the components required to implement a sophisticated and reliable monitoring system (alarm relays etc.). See Figure 1 for location of features:

### 2.1 Front Panel Features

See Figure 1 for location of features.

LED	Description
<b>Power</b>	Green LED for Power
<b>AL3</b>	Red LED indication of Alarm Level 3
<b>AL2</b>	Red LED indication of Alarm Level 2
<b>AL1</b>	Red LED indication of Alarm Level 1
<b>Fault</b>	Yellow LED, Lower most, indication of Fault Condition
<b>Key Buttons, 4</b>	Menu – Main Select Switch Increase – Menu Option, used in setup & programming Decrease – Change Switch, used in setup & programming Alarm Acknowledgement – Horn Defect Switch
<b>Display</b>	Graphic Display simultaneously showing reading for each channel and sensor type

An Audible signal is also provided by a sounder mounted within Microcontroller module. This provides a local audible tone during alarm or conditions.

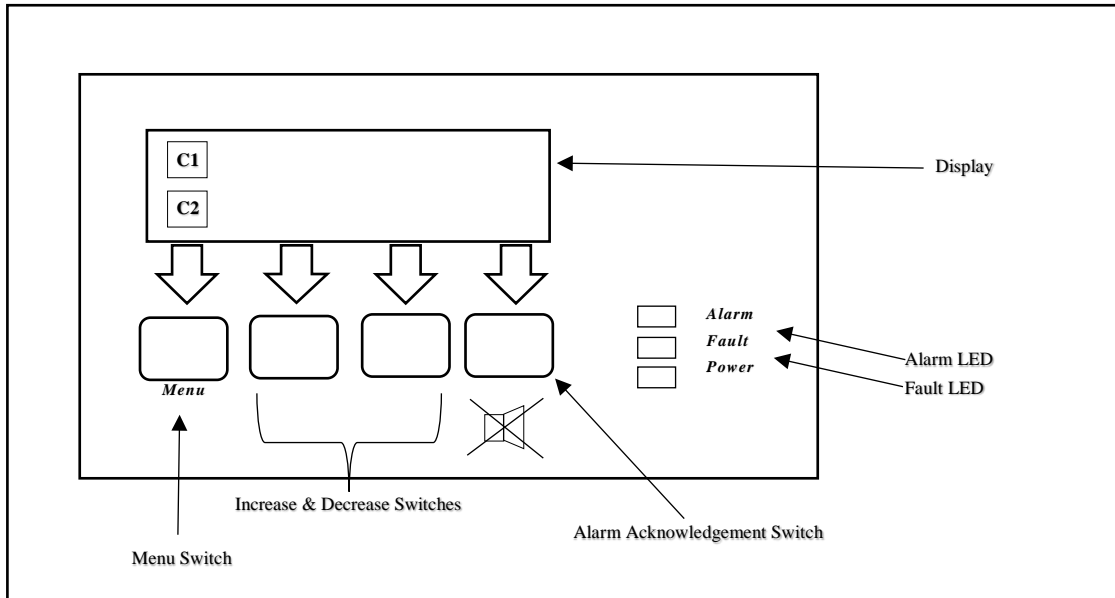

**Figure 1: LC Series Front Panel Features**

## 2.2 Installation

The LC-2 Controller is fully tested prior to delivery. However, it is recommended that the LC-2 Controller system be checked after installation is complete.

**CAUTION:** *The MCU Control Units and associated modules contain no user serviceable parts. Refer all servicing to qualified service personnel.*

The LC-2 Controller **must be mounted in non-hazardous location** where there is no risk of the presence of potentially explosive gas.

Either a 100-240 VAC 50/60 Hz supply or a 24 V DC supply can be used to power the control unit.

The location of installation should be chosen with regards to the following:

- This equipment should not be located near to known sources of heat.
- Operating personnel should be within convenient reach of the equipment and within hearing distance of audible alarms.
- Maximum loop lengths of cable run and cable inductance to resistance ratios must not exceed limits shown in the relevant loop diagrams.
- Avoid mounting this equipment near potential sources of electrical interference e.g. motors, switch gear, radio transmitters, etc.
- Mounting details for the LC-2 Controller enclosures are located below:

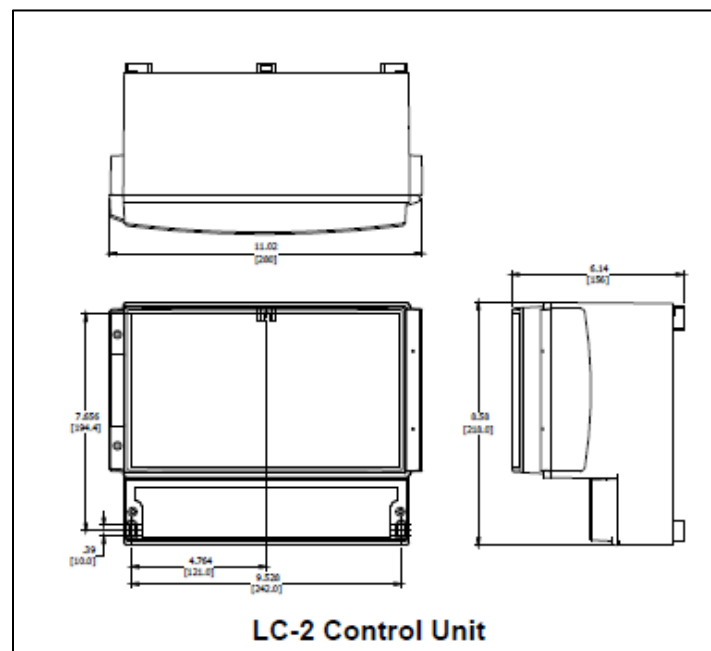

**Figure 2: Mounting the LC-2**

### 3.0 Wiring the LC-2

The electrical installation should conform to appropriate electrical codes, such as the National Electrical Code in the United States.

**WARNING:** *The compliance of the installation to appropriate codes is not ENMET's responsibility.*

#### 3.1 System Wiring

All connections should be made according to the appropriate sensor or loop diagram for the configuration required. It is advised that 'Bootlace Ferrules' or 'flat blade crimps' be used for tidy and reliable connections of wires into the Control Unit and Detector Head connectors.

#### Power Supply Input

An isolating switch should be provided between the power source and the MCU control units to allow the supply to be easily disconnected. This should be incorporated over current protection or a circuit breaker. Alternatively, a fused supply would suffice.

#### AC Mains Connection

The power supply board has three screw terminal connectors assigned for the connection of an AC supply.

Pin 1 = Earth

Pin 2 = Live Input

Pin 3 = Neutral Input

Recommendation for mains input cable. 3-Core – 16 AWG Conductors having cross sectional area of 0.75mm<sup>2</sup> minimum (24/0.2)

#### DC Voltage Connection

The power supply board has two screw terminals assigned for the connection of a DC supply

Pin 4 = +24V DC Input

Pin 5 = 0V DC Input

#### Cable Routing

Due to the low signal levels generated by gas detectors it is recommended that all wiring to the sensors be segregated away from AC mains or other high voltage/power lines to avoid interference.

#### Cable Screening

The use of a screened cable is recommended for the installation of all detector heads. The screening is used to minimize the effects of electrical interference generated by external equipment e.g. motors, switchgear, etc. The correct strategy for connecting the screens depends upon the area in which the detector head is to be used (i.e. hazardous/non-hazardous). In all cases the screen should not be connected at the detector head.

### 3.1.1 Power Supply Module

The power supply / circuit board is located under the display panel. Access to the power supply / circuit board is ONLY needed if the LC-2 fails to power up when AC or DC voltage is applied and to verify that Fuse 1 or Fuse 2 have not been damaged.

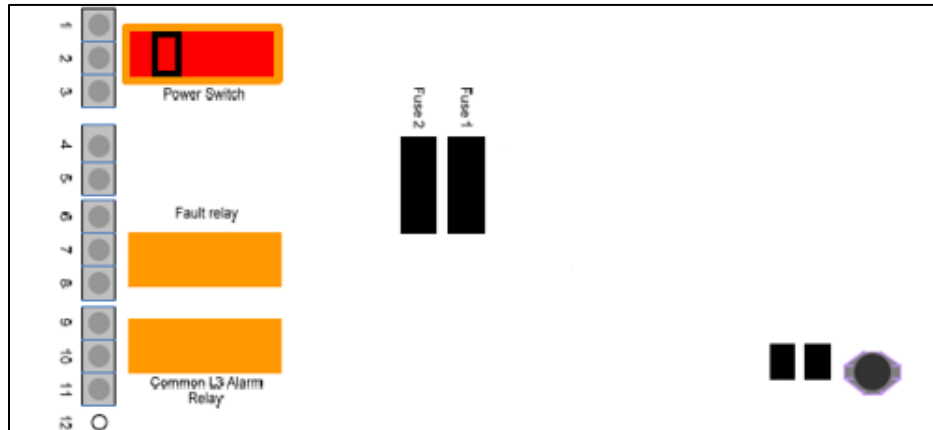

**Figure 3: Power Supply Module**

There are two power source options available to the system:

1. 100-240V AC Main Supply, connectors 1, 2, & 3
2. 18-28V DC Supply, Connectors 4 & 5

There are two fuses situated on the main PCB:

1. FS1 (T1/0A) – AC Supply Fuse
2. FS2 (T500mA) – DC Supply Fuse

The LC-2 Controller is a single PCB design. Each unit has a power supply section and a 2 I/O interface section.

Located on the bottom edge of the main PCB are screw connectors. These are used to provide connections for inputs, outputs and external buttons.

### 3.1.2 LC-2 Connections

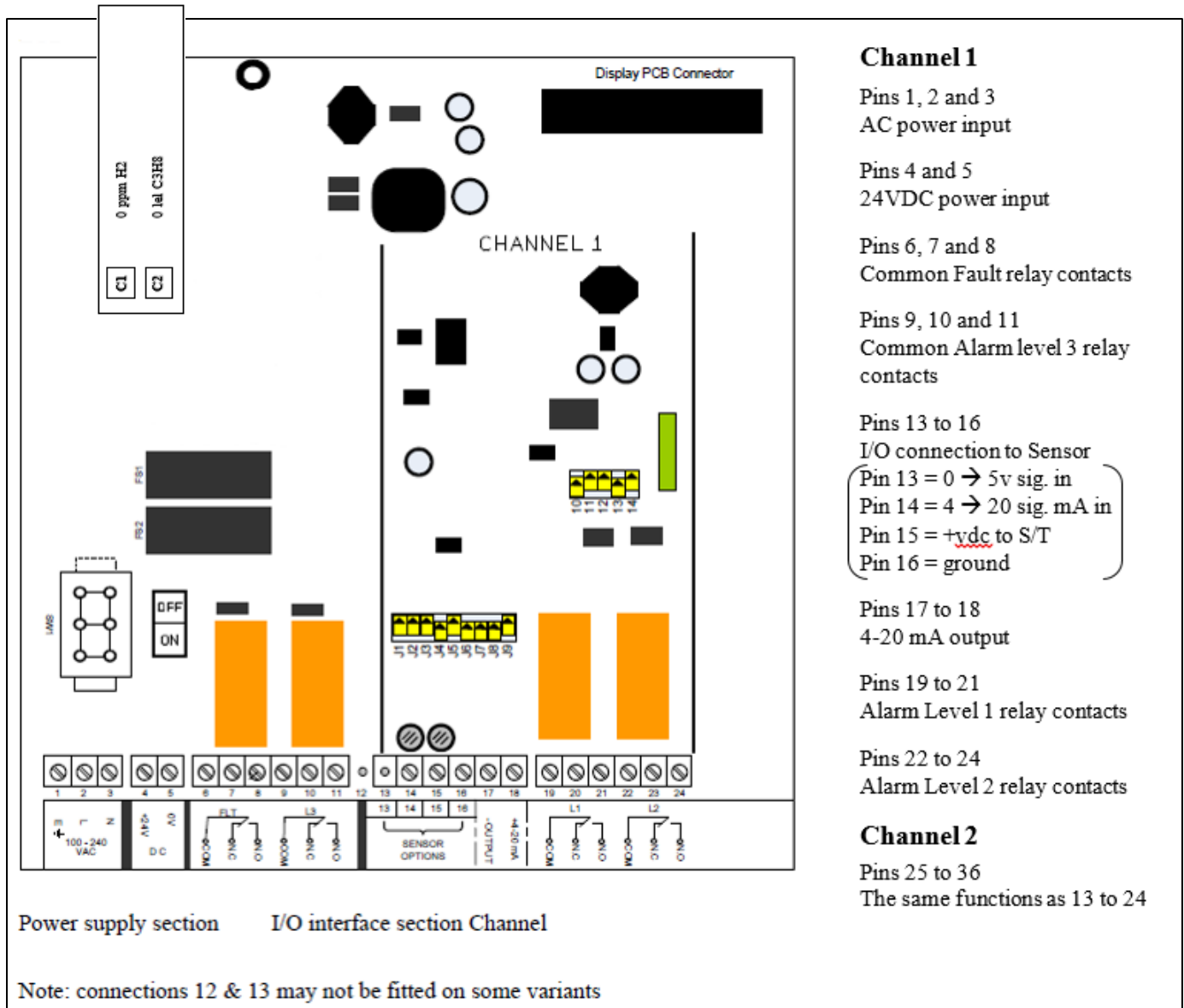

**Figure 4: LC-2 Connections**

The diagram above shows a pictorial representation of the various module positions within the LCU Series Control Units. The power supply is situated on the LHS of the main PCB with the channel I/Os to the right of the PCB.

The microcontroller module and LCD display are mounted on the top of the front panel. This connects to the main PCB via a single flat ribbon cable.

**NOTE:** Connections 12 & 13 may not be fitted on some variants.



### 3.2 Sensor Transmitter Installation

The mounting location for the gas detector must be considered. Initial points for consideration:

- Ensure all LC-2s are mounted to allow routine calibration and maintenance as required.
- Ensure the proposed site will not interfere with movement of existing equipment, e.g. cranes, doors, etc.
- Install all cables neatly and securely.
- Detectors for gases that are lighter than air should be positioned at, or below, head height.
- Detectors for gases that are heavier than air should be located at below head height.
- Avoid locating the LC-2 adjacent to potential sources of radio frequency interference, e.g. radio transmitters, control switchgear, motors, etc.
- Ensure LC-2(s) are mounted with sufficient space to allow air movement around the sensor section.

#### 3.2.1 Example 2 Wire Sensor Transmitter

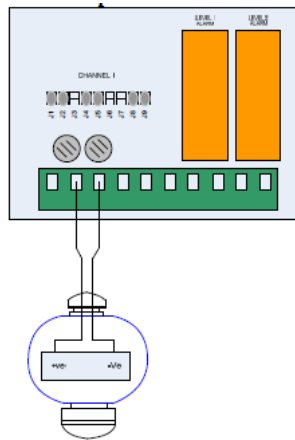

#### 3.2.2 Example 3 Wire Sensor Transmitter

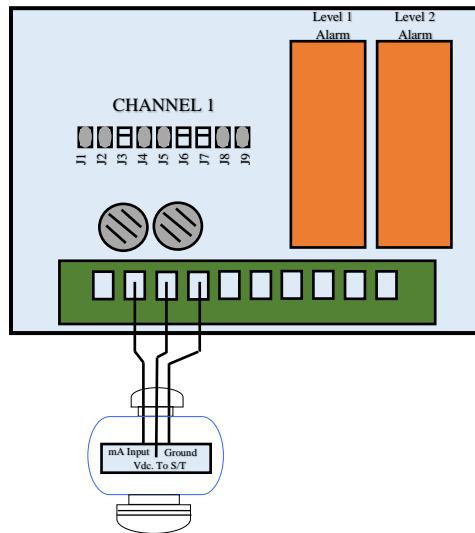

## 4.0 Operation

When a preset alarm point is reached, visual and/or audio alarms are activated. The backlit graphics display automatically displays the channel in alarm and alarm level LED(s) are activated on the control panel.

### 4.1 LC-2 Microcontroller Module

Situated within the LC Control Unit front panel is the Microcontroller Module. This module communicates with all Input channels connected to the system PCB.

The Microcontroller Module provides a user interface in the form of a back lit graphics display and a four-button multifunction keypad.

Three LED indications are provided directly by the Microcontroller Module and these are visible via MCU front panel:

- Green LED for power
- Red LED indication for Alarm level 1
- Red LED indication for Alarm level 2
- Red LED indication for Alarm level 3
- Yellow LED indication of fault condition

An audible signal is also provided by a sounder mounted within the Microcontroller module. This provides a local audible tone to signal that the instrument has detected gas outside of preset conditions.

The Microcontroller Module also provides the user with many configuration and interrogation facilities via the LCD and keypad. These facilities include:

- Sensor Configuration
  - Allows adjustment of sensor type and range (e.g. Flammable 100% LEL)
- Calibration of the System
  - This allows each channel to be calibrated independently. The sensor zero point and span can both be set via this function.
  - Calibration of the retransmitted output for each channel.
  - Calibration of the channel power supply.
- Input Module Relay Configuration
  - Each input module contains two relays for alarm levels 1 and 2. The alarm levels can be individually set to be either rising or falling.
  - Fault relay.
  - All relays can be configured normally energized or de-energized as required. Latching and non-latching functions can also be selected.

The Microcontroller module contains all the software required to communicate with up to two detecting channels.

### 4.2 Connection Procedures

- Disconnect power from the system.
- Remove the terminal cover to gain access to the wiring.
- Remove the terminal cover and display module to gain access to the configuration link settings.
- Configure the jumper switches as shown below (i.e. J1, J2, J4, J5, J8 and J9 switched ON, all others OFF)

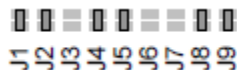

- Connect the wires from the detector head to the connector on the input module observing the following:

Detector Head Label 4-20 mA Loop	Channel 1 Pin Number	Channel 2 Pin Number
-	14	26
+	15	27

- Connect power to the system and ensure the detector head operates (text on LCD, LED will flash approximately every six seconds).
- Perform software configuration (refer to 'LC Software Configuration and System Calibration Manual').
- Perform system calibration (refer to 'LC Software Configuration and System Calibration Manual').

### 4.3 Analogue Output Configuration

In addition to providing the connections for various connector types, the Input Module can also provide an analogue output. This output mimics the signal detected so that it may be used by external equipment (e.g. chart recorders, data loggers) for a variety of purposes.

**NOTE:** *It is important to ensure that the analogue output is calibrated if in use (refer to 'MCU Software Configuration and System Calibration Manual')*

4.3.1 4-20mA Current Source

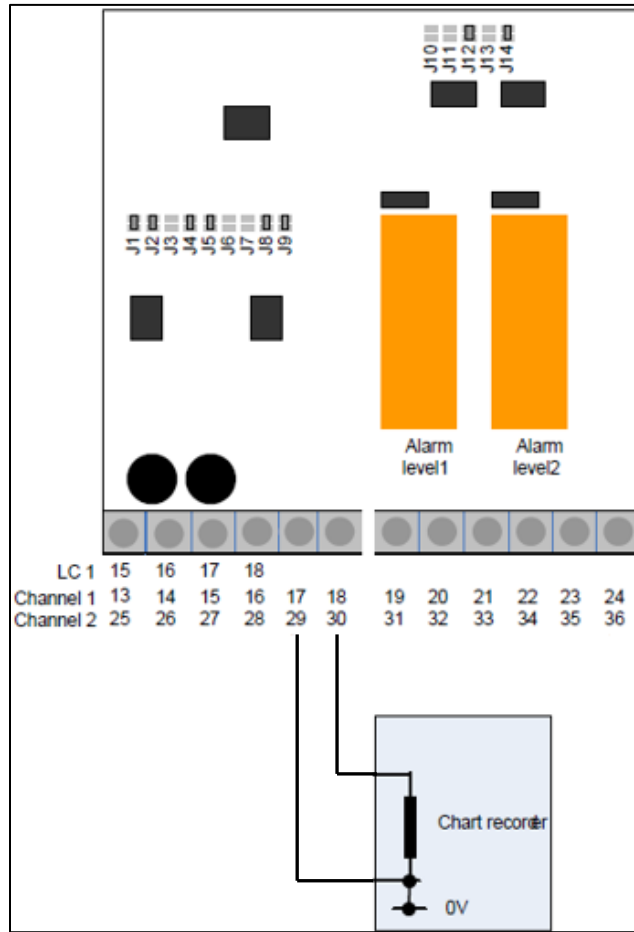
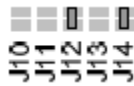

Figure 5:4-20mA Current Source

The Input Module sources a current proportional to the detected gas level. (i.e. zero gas = 4mA; full scale = 20mA)

The supply is taken from the internal PSU. Switch ON J12 and J14.



**NOTE:** Incorrect jumper switch configuration can cause damage to the system.

### 4.3.2 4-20mA Current Sink

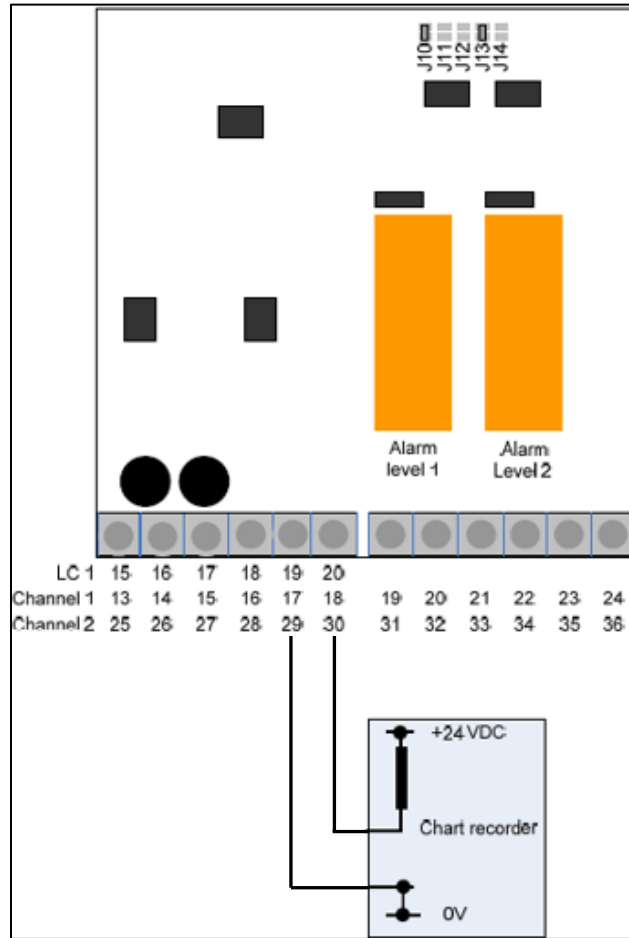

**Figure 6: 4-20mA Current Sink**

The Input Module can also sink a current proportional to the detected gas level. (i.e. zero gas = 4mA; full scale = 20mA)

The supply is derived from the external equipment. Switch ON J10 and J13.

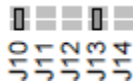

**NOTE:** *Incorrect jumper switch configuration can cause damage to the system.*

### 4.3.3 1-5V Voltage Output

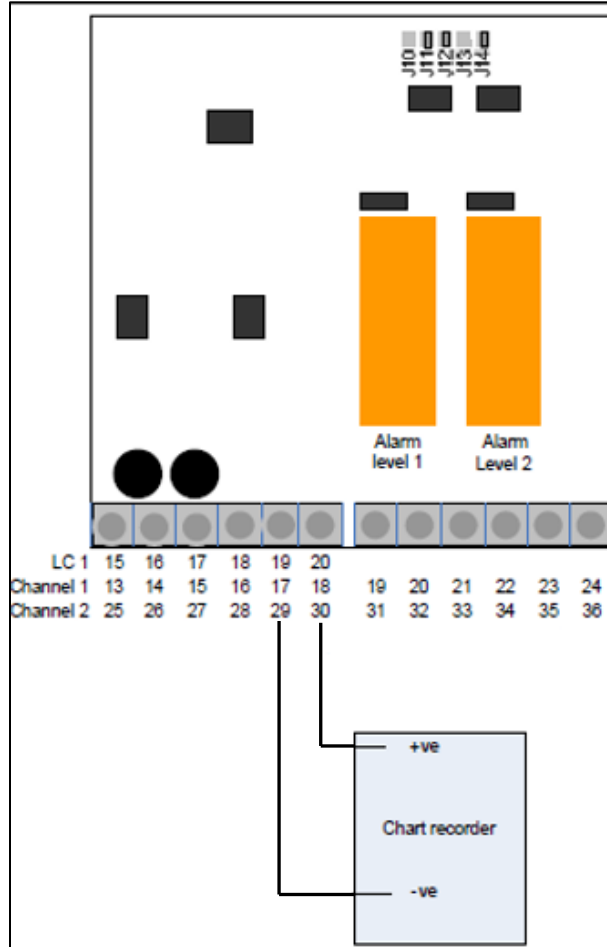

**Figure 7: 1-5V Voltage Output**

The LC-2 Controller can provide a voltage output. (i.e. zero gas = 1V; full scale = 5V)

This output is not ideal when transmitting a signal over a large distance. The resistance of a cable attached will cause a voltage drop to occur.

Switch ON J11, J12 and J14.



**NOTE:** *Incorrect jumper switch configuration can cause damage to the system.*

## 5.0 Maintenance

### Routine Servicing

The MCU Control Unit will provide a reliable and fault free service but they rely upon sensible housekeeping and regular calibrations. It is recommended that the system be calibrated **at least** once every six months. This can be arranged with Status Scientific Controls as part of a maintenance contract.

### Routine Inspection

It is advisable to periodically inspect the LC-2 Controller unit installation:

- Check cables to ensure no damage has occurred.
- Clean control unit casing using a clean cloth.
- Clean detector heads using a clean DAMP cloth.

**NOTE:** *Use of a dry cloth would constitute a static hazard.*

- Inspect detector heads and ensure the sensor housings aperture is not obstructed.

**NOTE:** *Do not use solvents to clean the LCD display window on the control units or the detector heads*

The time interval between routine inspections will depend upon the area in which the equipment is installed. A clean laboratory installation may only require inspection at the time of calibration, whereas an installation in a particularly dirty environment may require weekly inspections. It is the responsibility of the system engineer to assess the installation environment and determine the frequency of routine inspections.

## 6.0 Technical Data and Specification

### LC-2

Type	LC-2
Size (nominal) 'mm'	280 x 219 x 156
Weight (approx.)	1.9Kg
Operating Temp	-10°C to +50°C
Storage Temp	-20°C to +50°C
Humidity Range	0 to 95% R.H. Non-condensing
Input Voltage	18-28V DC, or 100-240V AC 50/60
Environmental Rating	IP65

User Interface	
Display	Backlit 122 x 32 dot Liquid Crystal Display (LCD)
Keyboard	4 button multifunction keypad
LED Indication Option 1	Red Indicates the alarm condition Yellow Indicates the fault condition Green Indicates that the power is ON
LED Indication Option 2	Green Indicates that the power is ON Red Indicates the alarm level 3 condition Red Indicates the alarm level 2 condition Red Indicates the alarm level 1 condition Yellow Indicates the fault condition

Input Modules	
Number of channels	2 max
Signal Inputs x 2	4-20mA Current Loop from 24V source 4-20mA Current Loop sink to 0V. 3-Wire Pellistor Systems
Analogue Output x 2	4-20mA Current source is proportional to detected signal 4-20mA Current sink is proportional to detected signal 1-5V Voltage output proportional to detected signal
6 – Relays	1 relay is assigned to alarm level 1, channels 1 & 2 1 relay is assigned to alarm level 2, channels 1 & 2 1 relay is assigned to the common alarm level 3
Contacts Rating	1 fault relay Single Pole Changeover Contacts (voltage free) 5A 240V AC

Power Supply	
Fuse 1 (AC Input)	T1.0A
Fuse 2 (24VDC Input)	T500mA

**NOTE:** All specifications stated in this manual may change without notice.



## 7.0 Terms and Conditions

### 7.1 Ordering Information

Address orders to:

**ENMET**  
Attention: Customer Service Department  
680 Fairfield Court  
Ann Arbor, MI 48108

Email Orders: [orderentry@enmet.com](mailto:orderentry@enmet.com)

Phone: 734-761-1270

Fax: 734-761-3220

You may also contact our customer service department by email [info@enmet.com](mailto:info@enmet.com). MINIMUM ORDER IS \$50.00.

### 7.2 Delivery

Unless Seller otherwise specifies, delivery will be made: FOB Ann Arbor, MI and/or FOB Bowling Green, KY. Title and risk of loss shall pass to Buyer at that point. Shipping and handling charges will be Prepaid and Added to Buyer's invoice. Buyer may request shipping be charged to their own account with a preferred carrier. Seller shall have the right to choose means of transportation and to route shipment when specific instructions are not included with Buyer's order. Seller agrees to deliver the goods and services, within the time, in accordance with specifications, at the prices specified on the face hereof. Buyer's orders to this quotation are not subject to cancellation or deferment of delivery without indemnification of loss to the Seller resulting therefrom. Seller shall not be liable to Buyer for any loss or damage sustained on account of this delay or nonperformance due to causes beyond Seller's control and without his fault or negligence. Where performance of the terms here is contingent upon timely delivery of goods or services by the Buyer and such delivery is in default, Seller shall be indemnified for any damage or loss resulting therefrom, and/or by extension of Seller's delivery commitment, as applicable.

### 7.3 Payment Terms

Payment Terms are Net 30 Days from the date of shipment from Seller unless otherwise noted. All shipping and handling costs will be charged to Buyer on a Prepaid and Add basis. Buyer has the option of paying for shipping by charging its own account with a carrier

### 7.4 Warranty Information and Guidelines

The Seller warrants new instruments to be free from defects in workmanship and material under normal use for a period of one year from date of shipment. The warrant covers both parts and labor excluding calibration and expendable parts such as filters, detector tubes, batteries, etc. If the inspection by the Seller confirms that the product is defective, it will be repaired or replaced at no charge, within the stated limitations, and returned prepaid to any location in the United States. The Seller shall not be liable for any loss or damage caused by the improper use or installation of the product. The Buyer indemnifies and saves harmless the Seller with respect to any loss or damages that may arise through the use by the Buyer or others of this equipment. This warranty is expressly given in lieu of all other warranties, either expressed, implied or statutory, including that of merchantability, and all other obligations, or liabilities of ENMET, LLC for damages arising out of or in connection with the use or repair or performance of the product. In no event shall ENMET, LLC, be liable for any indirect, incidental, special or consequential damages or for any delay in the performance by ENMET, LLC, which may arise in connection with this equipment. ENMET neither assumes nor authorizes any representatives or other persons to assume for it any obligation or liability other than that which is set forth herein. Buyer agrees to indemnify and save harmless Seller for any damage or loss from lawsuits against Seller by reason of manufacture of sale of materials, parts, or use of processes resulting from Buyer's design specifications. Any patent, design, pattern, tool, die, jig, fixture, drawing, test equipment, or process furnished by Seller; whether possessed by the Seller before the date of this quotation, or devised or acquired by Seller during performance of the terms of this quotation, shall remain the property of the Seller except by specific stipulation on the face hereof. Seller reserves the right, without liability, for damage or loss, to destroy Buyer's drawings, specifications, patterns and special tools supplied by Buyer for performance of the terms on the face hereof, unless Buyer gives notice of the disposition of such items.

### 7.5 Return Policy

**All returns for credit must be approved in advance by ENMET, LLC.** Such returns are subject to a minimum \$50.00 or 20% restocking charge, whichever is greater. **Approval of equipment for return is totally at the discretion of ENMET, LLC.** All requests for return/exchange must be made no later 30 days of the original shipping date from ENMET. The actual amount of any resulting credit will not be determined prior to a complete inspection of the equipment by ENMET. Calibration gas cylinders cannot be returned or restocked.

## 8.0 Instructions for Returning an Instrument for Service

Contact the ENMET Service Department for all service requests.

Phone: 734-761-1270

Email: [repair@enmet.com](mailto:repair@enmet.com)

Fill out the “Service Request Form” found at the end of this manual and return with your instrument for all needs. Please send your instrument for service to the site in which the product was purchased. A new “Service Request Form” may be requested if the one found in the manual is not available. All instruments should be shipped prepaid to ENMET.

Address for Service:

Michigan Location:

**ENMET**  
Attention: Service Department  
680 Fairfield Court  
Ann Arbor, MI 48108

Kentucky Location:

**ENMET**  
62 Corporate Court  
Bowling Green, KY 42103

Providing the “Service Request Form” assists in the expedient service and return of your unit and failure to provide this information can result in processing delays. **ENMET** charges a one hour minimum billing for all approved repairs with additional time billed to the closest tenth of an hour. All instruments sent to **ENMET** are subject to a minimum evaluation fee, even if returned unrepared. Unclaimed instruments that **ENMET** has received without appropriate paperwork or attempts to advise repair costs that have been unanswered after a period of 60 days may, be disposed of or returned unrepared COD and the customer will be expected to pay the evaluation fee. Serviced instruments are returned by UPS/FedEx Ground and are not insured unless otherwise specified. If expedited shipping methods or insurance is required, it must be stated in your paperwork.

**NOTE:** *Warranty of customer installed components.*

For Warranty Repairs, please reference **ENMET's** “Warranty Information and Guidelines” (found earlier in this section).

**Mailing/Shipping Address:**

ENMET  
680 Fairfield Court  
Ann Arbor, MI 48108  
[repair@enmet.com](mailto:repair@enmet.com)



**Phone: 734.761.1270**  
**Fax: 734.761.3220**

**Service Request Form**

**Product Name or Number:**

**Product Serial Number:**

**Describe Problem or Needed Service:**

**Warranty Claim?**  Yes  No

**CUSTOMER INFORMATION**

**Billing Address:**

**Shipping Address:**

\_\_\_\_\_  
\_\_\_\_\_  
\_\_\_\_\_

**Contact Name:** \_\_\_\_\_

**Phone #:** \_\_\_\_\_

**Email:** \_\_\_\_\_

**Fax #:** \_\_\_\_\_

**PO/Reference**

**#:** \_\_\_\_\_

**PAYMENT METHOD**

- COD  VISA/MasterCard  American Express

Card Number

Exp. Date

Security Code:

**Name as it Appears on**

**Card:** \_\_\_\_\_

**RETURN SHIPPING METHOD**

- UPS Ground  UPS 3 Day Select  UPS Next Day Air  UPS ND Air Saver  UPS 2 Day Air

UPS Account #: \_\_\_\_\_

- FedEx Ground  FedEx Air Express Saver  FedEx Air Overnight Std.  FedEx Air 2 Day  FedEx Air Overnight P-1

FedEx Account #: \_\_\_\_\_

Insure Shipment:  Yes  No

Insurance \$  
Amount: \_\_\_\_\_