

AM-5150

Single-Point Hazardous Gas Monitor for Ambient Air with Remote or Integral MOS Sensor

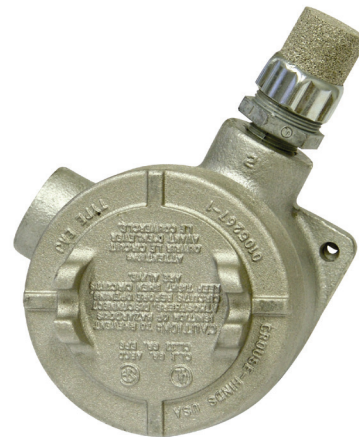

PRODUCT HIGHLIGHTS

- **Single-point broad range gas monitoring**
- **Audio and visual alarms**
- **User programmable alarms and high capacity relays**
- **Long-life rugged MOS sensor**
- **Easy to install compact design**
- **Available with remote or integral sensor**

AM-5150 is a compact, easy to install and operate single-point ambient air monitor featuring a rugged, long-life metal oxide semiconductor (MOS) sensor. AM-5150 can be used for the detection of various combustible gases, toxic hydrocarbon and organic solvents at ppm or percent LEL levels. The instrument can be optimized and calibrated for a particular gas or group of gases, but the MOS sensor is inherently non-specific. AM-5150 is a low cost, simple solution when non-specific gas detection is required where unknown toxic gases may be present.

An MOS sensor consists of a heated mixed metal oxide element that detects the concentration of various types of gases by measuring the resistance change of the metal oxide due to adsorption of gases. Atmospheric oxygen residing on the MOS surface is reduced by the target gases, allowing more electrons in the conduction band of the metal oxide material. Operating characteristics of MOS gas sensors are dominated by

reactions at the metal oxide surface. The change in resistance of the MOS material caused by the target gas can be measured with a simple voltage divider circuit and a reference resistor. MOS sensors have a long life, low power requirements and can operate in wide ranging temperatures, particularly high temperatures, as well as in extremely dry conditions.

AM-5150 is available with the sensor provided as an integral component attached to the instrument or with the sensor in a separate junction box for remote mounting up to several hundred feet from the monitor. The instrument includes a backlit digital display with audio and visual alarms with three user programmable alarm levels. This instrument provides high capacity user programmable relays designed for turning on other safety or warning equipment such as fans, horns, warning lights, etc. AM-5150 is a low-cost alternative for single-point ambient air monitoring when broad range detection is required.

AM-5150

GENERAL SPECIFICATIONS

Display:	High-contrast, backlit
Alarms:	Visual Gas Alarms: 3 red LEDs Audible: 105 dB at 30 CM (12 inches) All three alarms are user adjustable
Alarm Relays:	4 Form C, 10A SPDT contacts, 3 gas alarms and 1 fault
Operating Power:	100 to 240 VAC and/or 24 VDC, 15 Watts
Power Connection:	Supplied with strain relief for: 0.20" to 0.35" OD Cable
Inputs/Outputs:	Analog: 4-20 mA Digital: RS-485 Modbus
Operating Temperature:	-32° to +122°F (0° to +50°C)
Enclosure:	Polycarbonate
Dimensions:	7.1 W x 6.1 H x 3.5 D inches (18.2 W x 15.5 H x 8.9 D cm)
Weight:	2 lbs. (0.9 kg)

Sensor Specifications:

Sensor:	Metal oxide semiconductor (MOS)
Response Time:	t_{90} = 30 to 180 seconds, depending on type of gas and calibration
Accuracy:	+/- 15% of reading
Temperature Range:	-4° to +122°F (-20° to +50°C) for remote sensor
Rating:	Designed for Class 2, Groups A, B, C & D

Remote Sensor Assembly:

Enclosure:	Aluminum
Dimensions:	6.7 W x 4.4 H x 3 D (17 W x 11 H x 8 D cm)
Weight:	4 lbs. (0.8 kg)
Wiring:	4-conductor; 16 AWG for up to 500 feet to monitor; (for longer distances, consult factory)

EXAMPLES OF SOME TYPICAL CALIBRATIONS

Gas	Range	Alarm Points
Acetone, ppm	0-2000 ppm	500, 750, 1000 ppm
Acetone, % LEL	0-50% LEL	10, 20, 40% LEL
Ammonia	0-300 ppm	50, 100, 200 ppm
Butane	0-50% LEL	10, 20, 40% LEL
Carbon monoxide	0-200 ppm	25, 35, 100 ppm
Gasoline	0-50% LEL	10, 20, 40% LEL
Hydrogen	0-50% LEL	10, 20, 40% LEL
Hydrogen sulfide	0-50 ppm	10, 15, 20 ppm
Isopropanol	0-400 ppm	100, 200, 300 ppm
Isopropyl alcohol	0-50% LEL	10, 20, 40% LEL
Methane	0-50% LEL	10, 20, 40% LEL
MEK	0-400 ppm	100, 200, 300 ppm
Methyl alcohol	0-400 ppm	100, 200, 300 ppm
Methyl chloride	0-200 ppm	25, 50, 100 ppm
Methylene chloride	0-200 ppm	25, 50, 100 ppm
Propane	0-50% LEL	10, 20, 40% LEL
Styrene, ppm	0-200 ppm	25, 50, 100 ppm
Styrene, % LEL	0-50% LEL	10, 20, 40% LEL
Toluene	0-50% LEL	10, 20, 40% LEL
Xylene, ppm	0-400 ppm	100, 150, 200 ppm
Xylene, % LEL	0-50% LEL	10, 20, 40% LEL

Contact ENMET regarding ranges and custom calibration requirements.

680 Fairfield Ct., Ann Arbor, MI 48108
800-521-2978 or 734-761-1270
www.enmet.com

Lit. no. AM-5150-111920-V1

Specification subject to change without notice



WARNING: Loss of primary power renders continuous gas monitors inoperative.
Contact factory for specifications and pricing for backup battery systems compatible with ENMET monitors.

DIMENSIONS

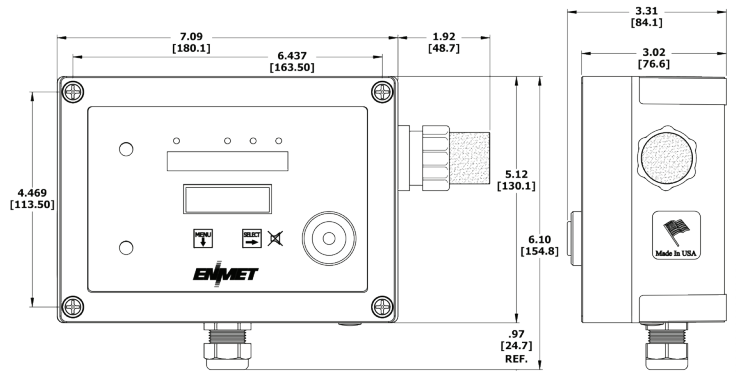

AM-5150 with attached MOS sensor option

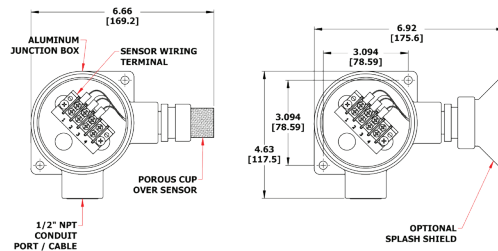

Remote sensor housing option

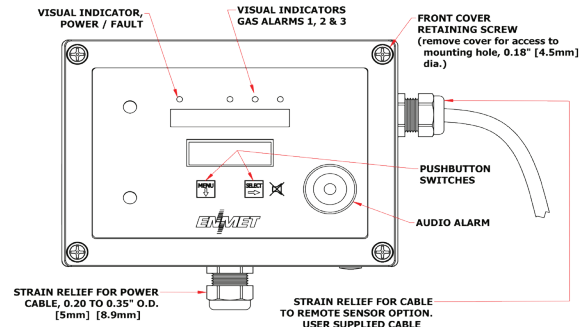

AM-5150 with strain relief for cable to remote sensor option

ORDERING INFORMATION

Description	Part No.
AM-5150 Monitor with remote sensor	10040-008
AM-5150 Monitor with integral sensor	10040-018
Calibration Regulator & Humidifier for AM-5150	03700-001
Gas Regulator Assembly for 34 liter steel gas cylinders	02506-004
Calibration Equipment Case	73083-000

Calibration Gas and Accessories - See price list

